

# Machine Vision & Imaging

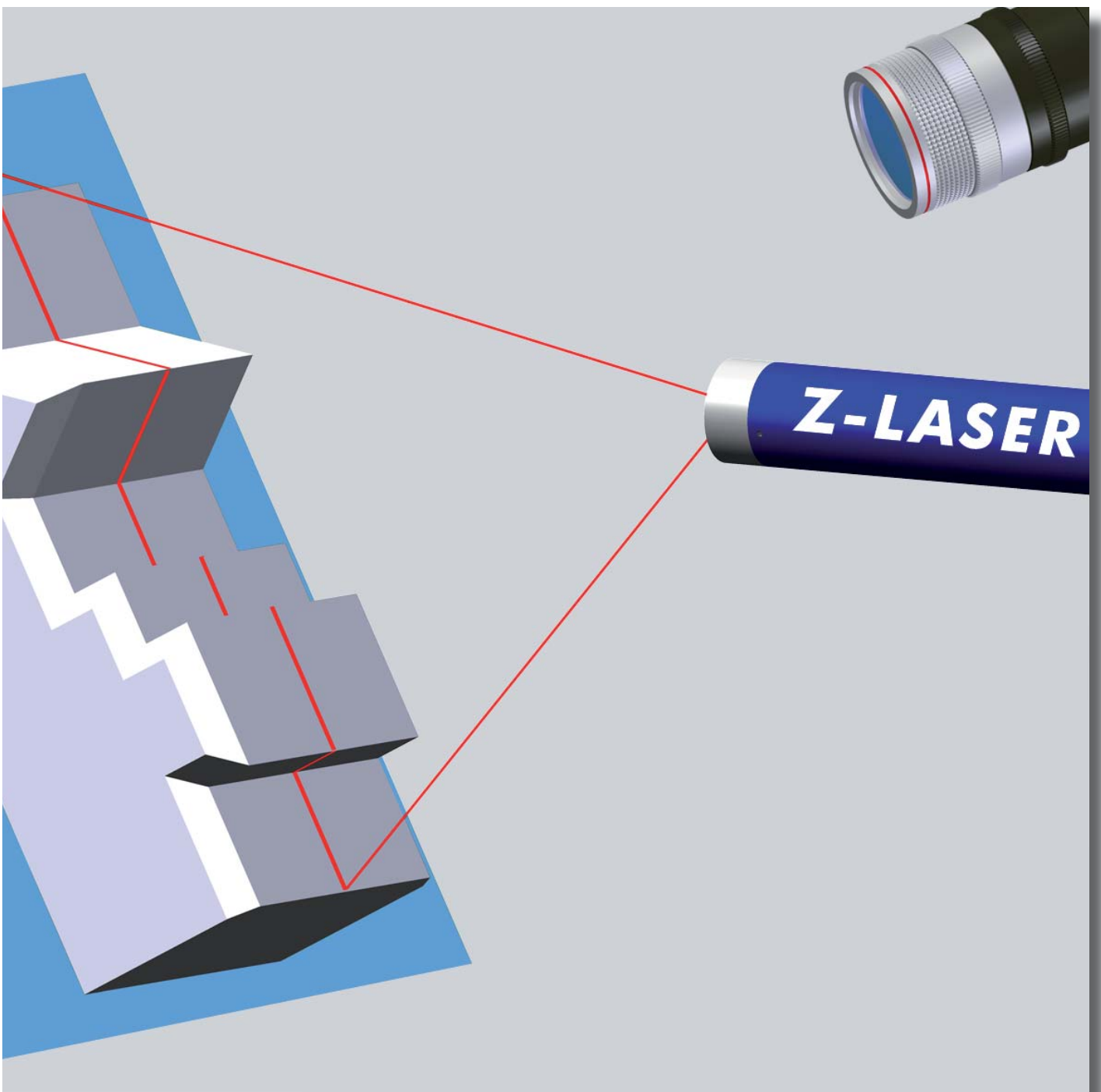

## Quality - Made in Germany

**Z-LASER** products have been designed and built in Freiburg (Germany) for more than 20 years. Printed circuit boards, housings and other components come from suppliers around Freiburg. Each laser is exactly adjusted to standard or customer specifications and is tested piece by piece before shipping.

Due to continuous production and cost optimization **Z-LASER** products are worth their price, which proves that quality products "Made in Germany" need not to be expensive at all. **Z-LASER** of course has been ISO 9001 certified for more than 10 years. In addition to that, all processes are regularly tested by industrial key customers according to their own quality standards. What our customers get is of continuous and testified high quality.

For customers who need a well documented product **Z-LASER** offers as a special service the individual certification of each product:

Line width, line straightness, intensity distribution along the length and perpendicular to the projected line, wavelength, spectrum, polarisation ratio etc. are available on demand.

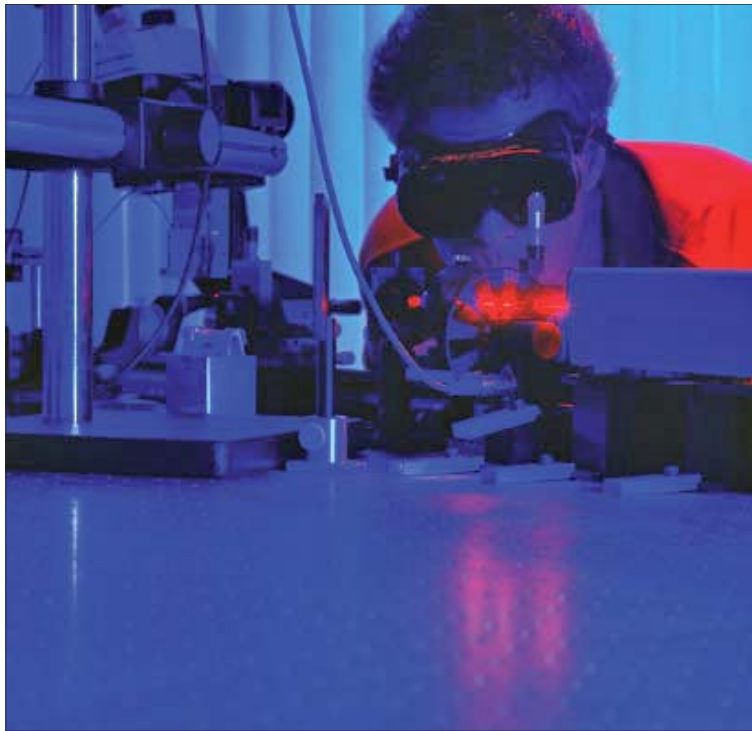

## Off-the-peg or tailor-made?

**Z-LASER** has developed and designed a large number of standard laser products during the years, but also builds many custom products, which are often not found in our standard catalogues.

If it is a variation of a standard laser, we even deliver single individual lasers. New products are even developed for small lots of 50 pieces and may consist one laser only or complete sub-assemblies ready for integration. Just contact us for more information.

# Laser Triangulation

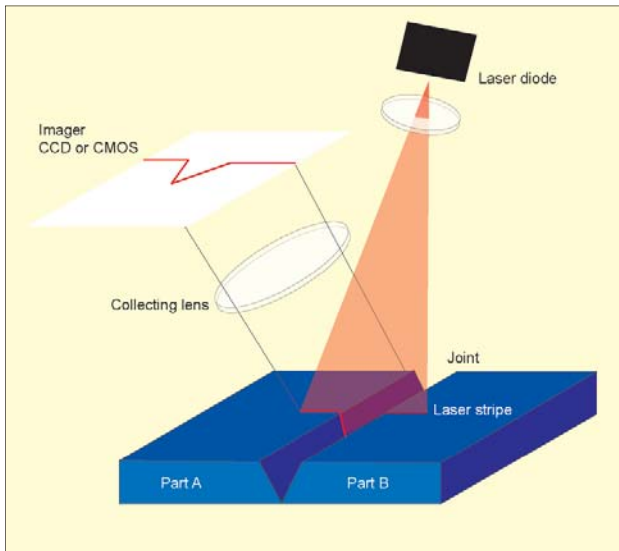

Use of a light structure and a camera allows at known angle the measurement of height differences and profiles on a test object.

Light structures can be points and point matrices, lines and line grids or circles and concentric circles.

Depending on the type of structure we distinguish between triangulation, light section or grid projection methods.

Depending on the angle between laser and camera one can either record small variations with high resolution or big variations with reduced resolution.

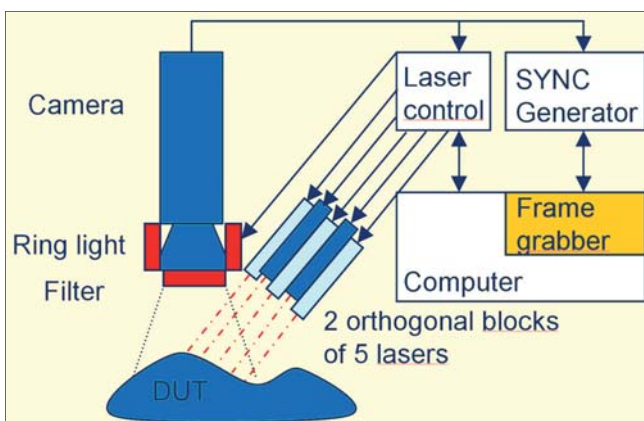
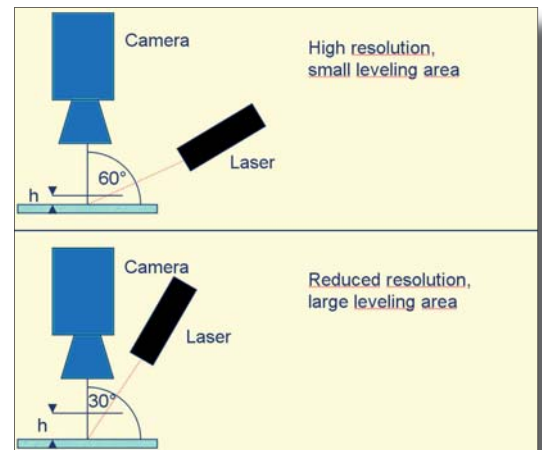

When using line grids there is always the risk to muddle up the lines as for example one line might be shadowed by the object. In such cases it is advantageous to use a block of several Super Mini line lasers which are separately switched on and off. This allows a failure-free distinction of which line is where.

If objects to be analyzed is not stationary but is in motion, the light source is modulated and synchronized with the image recording. Very high modulatable laser sources allow synchronization with the pixel read-out frequency.

## Depth of sharpness

If one wants to measure objects with the laser light section method the depth of sharpness is a further parameter: This is the range in which the line width is broadened not more than about the factor  $\sqrt{2}$ . Broader lines have a clearly higher range for the depth of sharpness than ultra thin lines. So it is important to find everytime the optimal compromise between line width and needed depth of sharpness for the respective application.

# Light Structures

## Points

In most of the applications the laser is angled while the camera is vertical mounted. So the resulting point projection has always an elliptic shape. In these cases the circularity of the point is not so important. If required, points with circular beam profile can be made.

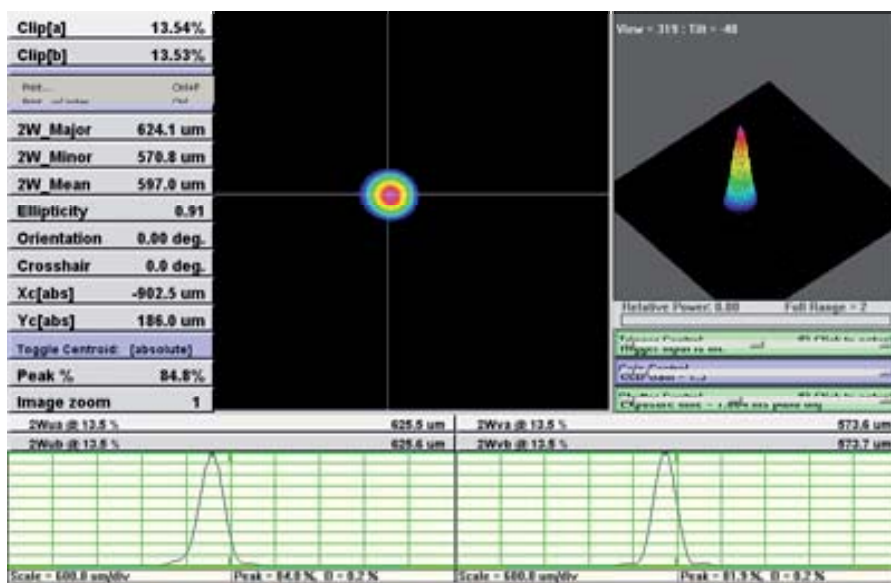

Circular beam profile

## Lines

### Equal or Gaussian intensity distribution

Line projections can be realized by using cylinder, raster or Powell lenses. Cylinder lenses produce a Gaussian light distribution along the line whereas the diameter of such a lens influences the fan angle and by this the line length. If one screens off the the border areas or if one only uses the maximum intensity of the line, such lines often show a quite homogeneous light distribution along the used area. Especially for small objects Gaussian lines with small fan angle are applicable as their line thickness is constant in the field of view.

If a non-Gaussian (=equal) light distribution along the line is essential, raster and Powell lenses are often used as line generating optics. But practice has shown that 15% intensity fluctuations are not unusual.

Calculations of an alternative optic concept have shown that intensity fluctuation smaller than 5% should be accomplishable. **Z-LASER** is working on the realisation of such an optic.

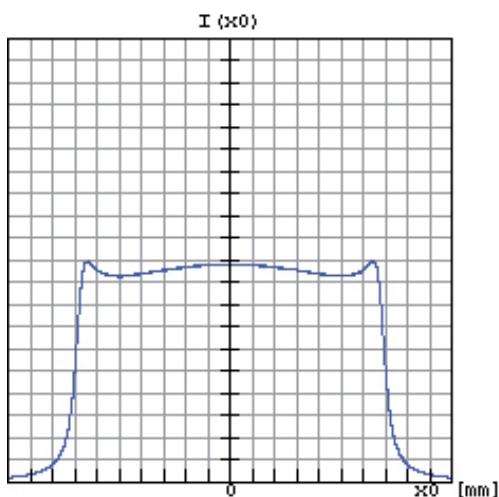

Cylinder lens



Powell lens

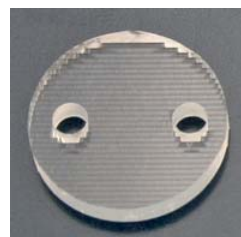

Raster lens

## Line width

Important for all applications is the optimal sharpness at given measurement distance. Typically one will use preferably fine lines to get a good resolution. Influence on the line width - or better to say: the visual impression - has not only the performance of the optic, but also - due to interferences - the structure of the substrate to be investigated.

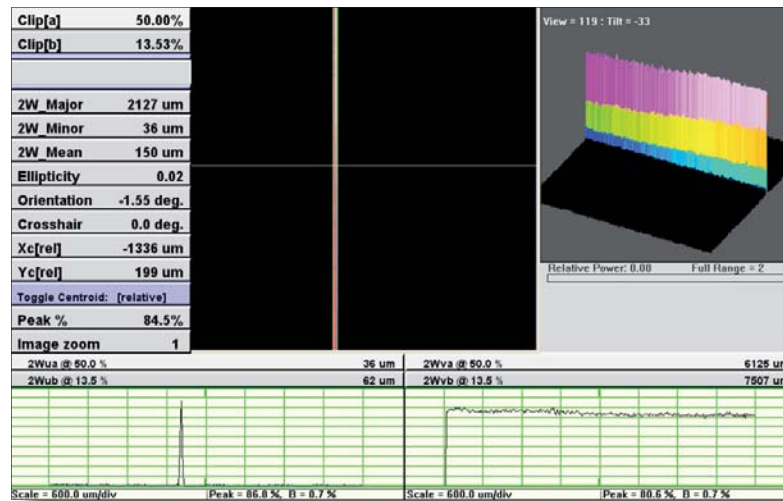

Line profile of a Powell lens 36  $\mu\text{m}$  (FWHM) at  $f = 135 \text{ mm}$

## Side lobes

Especially for exact measurements of small objects the line width has to be constant in the FoV (field of View). In addition the profile perpendicular to the line propagation should be Gaussian and have no or very low side lobes. Side lobes produce clutter that disturbs the measurement. If the distribution is Gaussian, sub-pixel resolution can be achieved by a Gauss-fit.

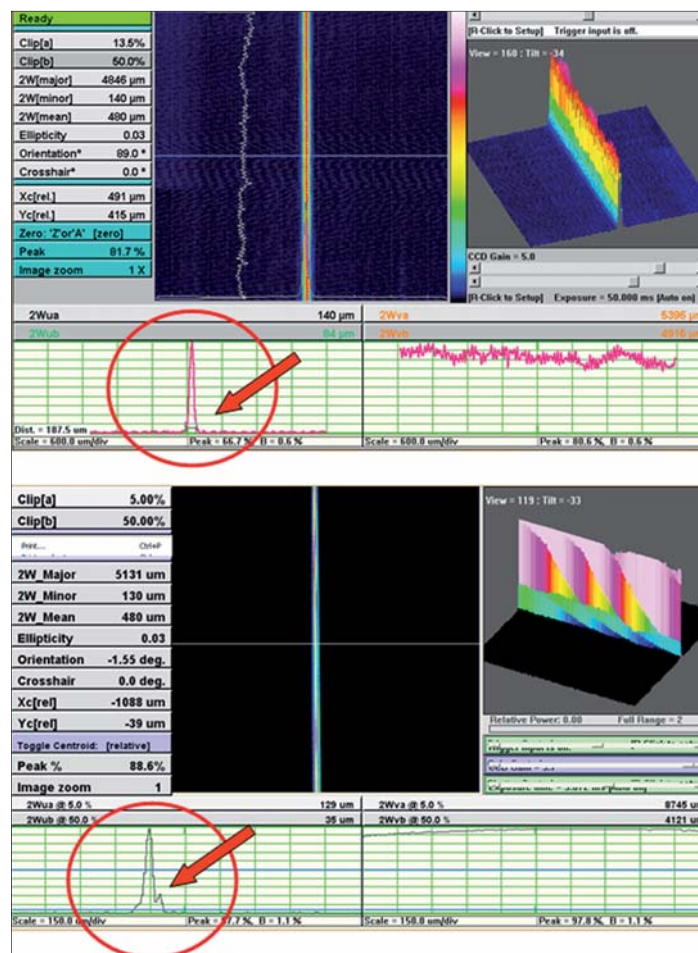

## Line Straightness

High quality laser lines can be manufactured with a very exact straightness of the line. Only if lines are straight, exact deformation measurements are easy to perform. Low cost products have often bent lines or have the shape of an „S“.

**Z-LASER** adjusts each line laser during the production process precisely to a straight line. Even for lines of several meters the variation is not more than 0.1 mm. On demand we will measure every line and enclose a test log in the delivery, which states the line width in the focus and the maximum variation from being a straight line.

## Other laser patterns

In addition to point and line structures many other projection patterns are used in machine vision: Crosses, circles, squares, dot-matrices, multi-lines, grids and many more.



Diffractive optical elements, or in short DOEs, are based on the principle of light diffraction on periodic micro-structures. By selective computer design of the surface structure beam shaping qualities as computer generated holograms or free-form phase functions can be realised. The cost effective manufacturing of DOEs is done by replication of a master (generated by e-beam direct writing lithography) on polymer or glass substrates. The quality of the projection depends on the quality of the hologram (depending on the used algorithm) as well as on the master and the replication process.

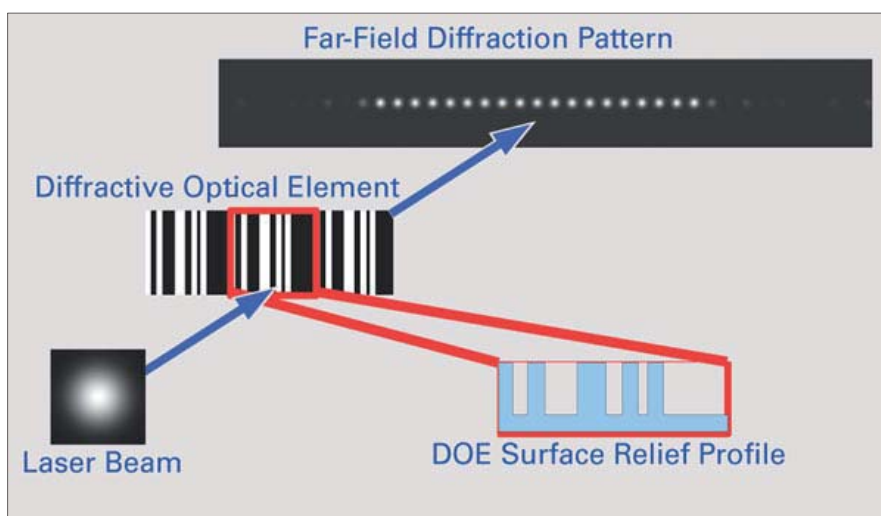

**Z-LASER** cooperates with selected experts in this field and is able to offer customer-designed DOEs in addition to standards projections as crosses, multi-lines, checkers, point matrices, circles, etc.

# Laser specific Properties

## Coherence creates Speckles

“Speckles” are generated due to the coherence of the laser radiation and disturb due to the distribution transversal to the laser line the sharpness of the edges and the homogeneity of the line. In general you can say that „speckles” on rough surfaces can only be reduced but not fully avoided. Reduction options are given by the use of superluminescence diodes (SLD) due to a diminished coherence length or relative movement between object and camera.

In superluminescence diodes the spontaneous emission processes overweigh only in the range of small injection currents, while with higher current rates the stimulated recombination is predominating. According to that, the characteristic curve runs initially very flat (during the period of spontaneous emissions), but then runs slowly over to a sharp increase (predominantly with spontaneous emission). The light which is emitted by superluminescence diodes – also in the range of the stimulated emission – is noncoherent due to the missing optical cavity.

## Center / Axis

Due to the production process, laser diodes may sometimes be enormously „cross-eyed”, i.e. they don’t emit centrally and coaxially to the housing. For some applications, e.g. Gaussian lines with small fan angles, the laser diodes have to be adjusted with adjusting screws centrally and coaxially to the laser housing. Lasers which are adjusted in this way then only have a minimal beam variation of 0.5 mrad or less, while not adjusted lasers typically have a beam variation of approx. 3 mrad.

## The wavelength of diode lasers is temperature dependent

The wavelength of diode lasers changes 0.019 nm/°C. If temperature changes the life-expectancy of a laser diode decreases enormously with increasing temperature (approx. 50 % per 10°C above room temperature). If temperature peaks only appear occasionally, an automatic switching-off at approx. 45°C is sufficient. If the laser is permanently exposed to temperature peaks, we would recommend an active cooling. Sometimes lasers also have to be operated at very low temperatures < -10°C. Then we would recommend to pre-heat the laser diode.

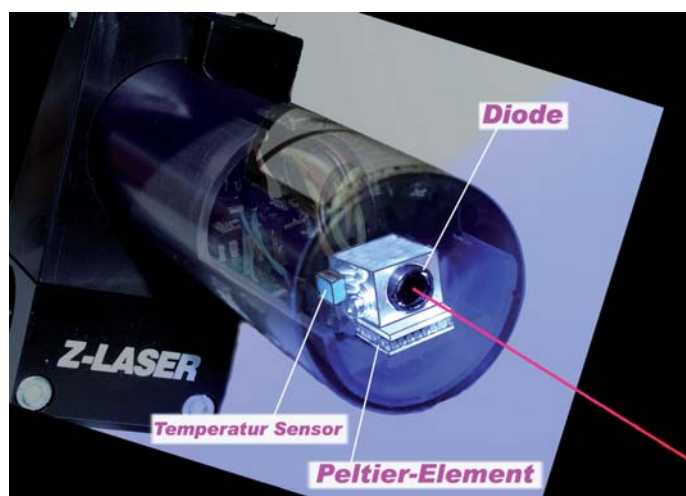

The ZQ series includes an integrated heating- and cooling system which keeps the laser constantly at room temperature. A temperature stabilisation is especially important when a high wavelength and pointing stability of the laser is required.

## Optimal Protection

Laser diodes are very sensitive electronic components which can be destroyed by slightest outside influences. For a high „life expectancy“ it is therefore very important to protect this component carefully.

Unlike many cheap products, all models of **Z-LASER** are – except for the Mini-series (where the dimensions make this impossible) – built potential-free and have a reverse battery protection, which protects the laser diode when accidentally mixing-up the negative and positive pole.

That means that no extra isolation for the lasers, when they are installed, is necessary. Isolation always means bad heat conduction, which leads to a stronger heating of the laser diode and a lower life-expectancy of the product.

Although the mains voltage parameters are standardized, Lasers still have to face various interferences, which may damage the laser. **Z-LASER** are extremely robust and can be used in the „heavy-duty“ version in rough industrial surroundings.

<p><b>Z-LASER</b> Heavy Duty mains supply</p> <p>Primary: 85 V~ - 265 V~, 47 - 63 Hz, no leakage current          Secondary: 5 VDC, 1,2 A, 3 W          Low RFI: EN 55022 B          Highest electro-magnetic immunity:          Lowest Coupling capacity input / output <math>C_k &lt; 25 \text{ pF}</math>          Clear width, leakage distance <math>\geq 8 \text{ mm}</math></p>	<p>Standards:</p> <p>ESD: EN 61000 - 4 - 2: 6 kV / 8 kV / air          HF-Field: EN 61000 - 4 - 3: 20V          Burst: EN 61000 - 4 - 4: 4 kV          Surge: EN 61000 - 4 - 5: 2 kV <math>R_i = 2\Omega</math>          HF Current: EN 61000 - 4 - 6: 10 V eff          Magnetic field: EN 61000 - 4 - 8: 30A/m          Power interrupt: EN 61000 - 4 - 11</p>
--	--

The biggest difference between our system and “normal” power supplies is the low coupling capacity  $C_k < 25 \text{ pF}$  between input and output, 0 mA leakage current and the soft switching behaviour of the power transistor. Thanks to the highly-developed concept there are only few EMC noises. The EMI sensitivity is about the factor 100 ... 1000 better than cheap power supplies, and at the same time with at least the same low EMI values e.g. EN 55022 B.

## Color



Typical wavelengths used in machine vision and imaging are in the red up to the near IR region. But in some cases other wavelengths such as blue or green can be beneficial for superior contrast. On metal surfaces blue lasers are often due to less reflectivity recommended.

Laser light is monochromatic. The collection of laser light with a camera can be drastically improved by use of band filters. They block all light except for a small wavelength band which can pass.

Image of a glue bead with and without band filter

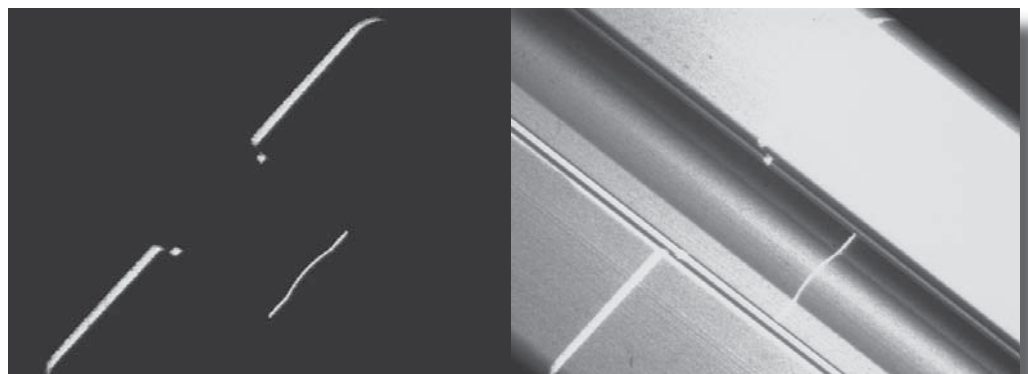

# Laser Power Stability

Depending on the application the laser power required can range from a few mW up to more than 1 Watt.

A continuous beam performance is guaranteed for diode lasers by the control electronics (APC = automatic power control) and photo diodes for feedback control.

For high power it is recommended to stabilise the laser in addition by thermoelectric cooling.

## Modulation

### TTL

In many applications the laser has to be switched on and off by a TTL-signal. It is very important, that the laser power is switched to full power without overshooting.

### Analogue

If the output power needs to be adjusted it can be done continuously by analogue control or by three preadjusted power levels.

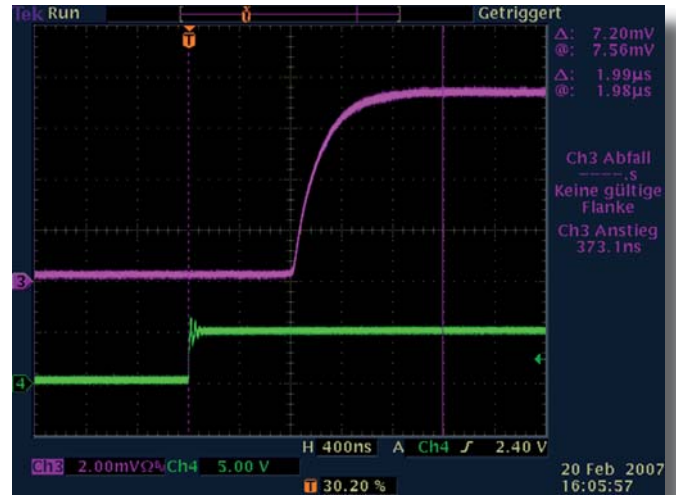

TTL-modulation

green: switching signal purple: optical signal

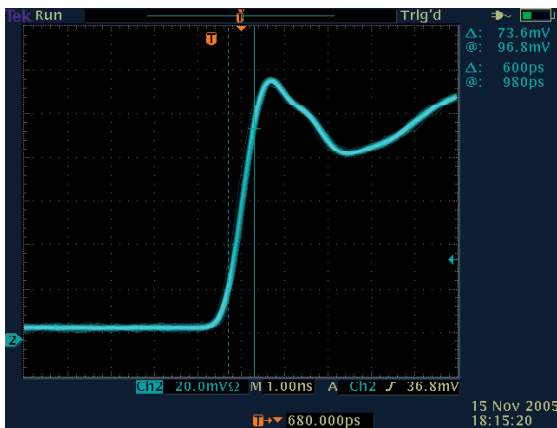

## High frequency modulation up to 100 MHz

For a quick recording of the measured values, e.g. for the registration of an object's movements, the laser has to be synchronised with the read out frequency of the camera. If you want to read out single pixels synchronously, you will quickly reach modulation frequencies for the laser in the MHz-range. Important for a modulation is the rise and fall time of the optical signal. Depending on your needs **Z-LASER** offers lasers modulatable to up to 100 MHz.

Rise- / Fall time < 1 ns @ 35 mW

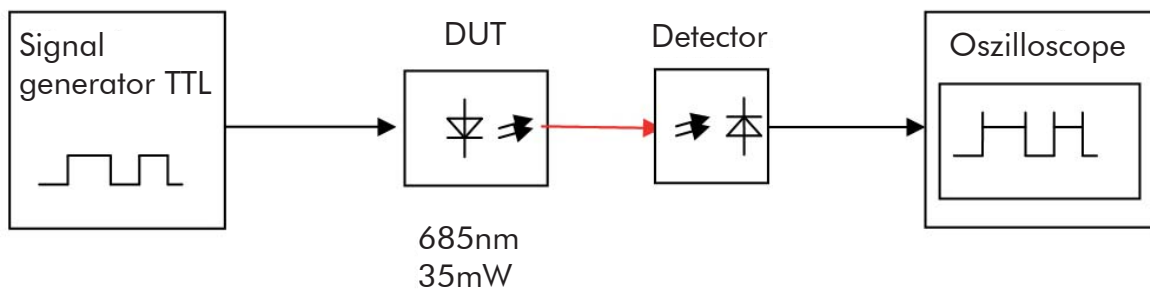

Measuring construction: Peak-value controlled 35 mW laser for operating in a range of CW to 10 MHz.

## Z-LASER Models for Imaging

	ZB	ZD	ZN	ZV	ZPT	ZQ
<b>Optics</b>						
focusable	no	no	no	yes	yes	yes
Gauss Line 3°/5°/10°/15°/20°/30°/ 90°	no	yes	yes	yes	yes	yes
Powell Line 30°, 45°, 60°, 75°, 90°	no	no	yes	yes	yes	yes
Raster line 20°, 40°	yes	yes	yes	yes	yes	yes
Elliptic dot	yes	yes	yes	yes	yes	yes
Circular dot	no	yes	yes	yes	yes	yes
DOE multi lines, grids, circles, concentric circles crosses etc.	no	yes	yes	yes	yes	yes
<b>Control options</b>						
Modulation up to 20 kHz	no	no	yes	yes	no	yes
Modulation up to 100 MHz	no	no	yes	yes	no	no
variable intensity control	no	yes	yes	yes	no	yes
3 level intensity control	no	no	yes	yes	no	no
active temperature control	no	no	no	no	yes	yes
<b>Diode laser</b>						
blue, red, infrared in vari- ous wavelengths and power	yes	yes	yes	yes	yes	yes
Maximum power	3 mW	30 mW	90 mW	90 mW	90 mW	up to 1 W
<b>DPSS laser</b>						
green	no	no	no	no	no	yes
Maximum power						20 mW

**Please note:**

**All dimensions in the schematic drawings of the lasers and brackets in the following pages are given in millimeters.**

## ZB - Super Mini Diode Laser

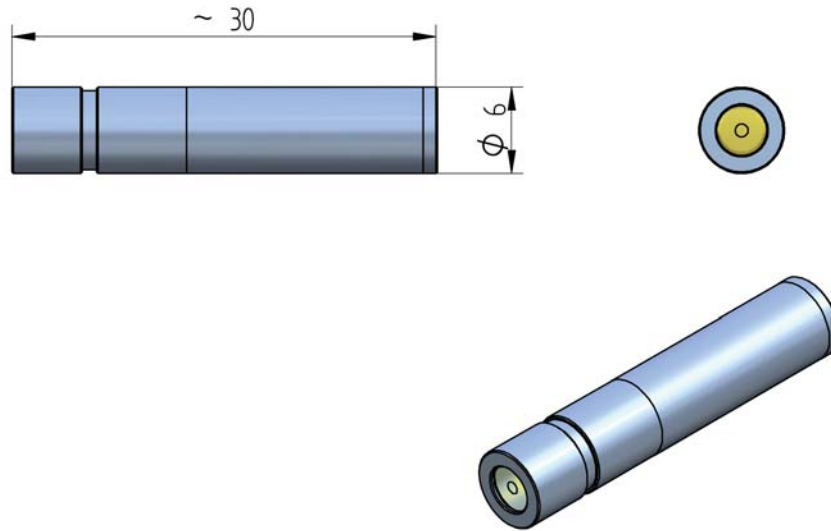

<b>Laser type:</b>	Diode laser up to 3 mW
<b>Laser class:</b>	depending on design
<b>Operating voltage:</b>	5V DC
<b>Electronics:</b>	APC control, no modulation or intensity control
<b>Electr. connection:</b>	Cable with Texas-plug, 2-pole or twin-wire cord
<b>Housing:</b>	stainless steel
<b>IP protection class:</b>	IP50
<b>Optics:</b>	Dot, Raster lens -lr20 (only for short distances up to 500 mm)
<b>Point spot quality:</b>	elliptic
<b>Line quality:</b>	equally distributed intensity along the line
<b>Focus ability:</b>	for Point yes, Line: fixed focus

### Electrical connector:

Pin 1 Plus 5V/DC  
Pin 2 GND

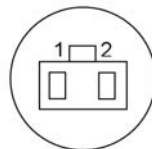

**When mounting the laser it has to be electrically insulated (Positive Potential on the housing due to housing size), at the same time it should be mounted thermally conducting for a better heat flow.**

## ZD - Mini Diode Laser



<b>Laser type:</b>	Diode laser up to 30 mW
<b>Laser class:</b>	depending on design
<b>Operating voltage:</b>	5V DC / 24 VDC option
<b>Electronics:</b>	APC control
<b>Option:</b>	intensity control (3rd wire)
<b>Electr. connection:</b>	Cable with Texas-plug, 2-pole or twin-wire cord or Texas socket
<b>Housing:</b>	chromed brass
<b>IP protection class:</b>	IP63
<b>Optics:</b>	Point, Cylinder lens, Raster lens, DOE
<b>Point spot quality:</b>	elliptic or circular
<b>Line quality:</b>	Gaussian or equally distributed intensity along the line
<b>Focus ability:</b>	factory adjusted according to customer specification

### Electrical connector

Pin 1 Plus 5V/DC  
Pin 2 GND

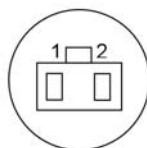

## ZN Diode Laser

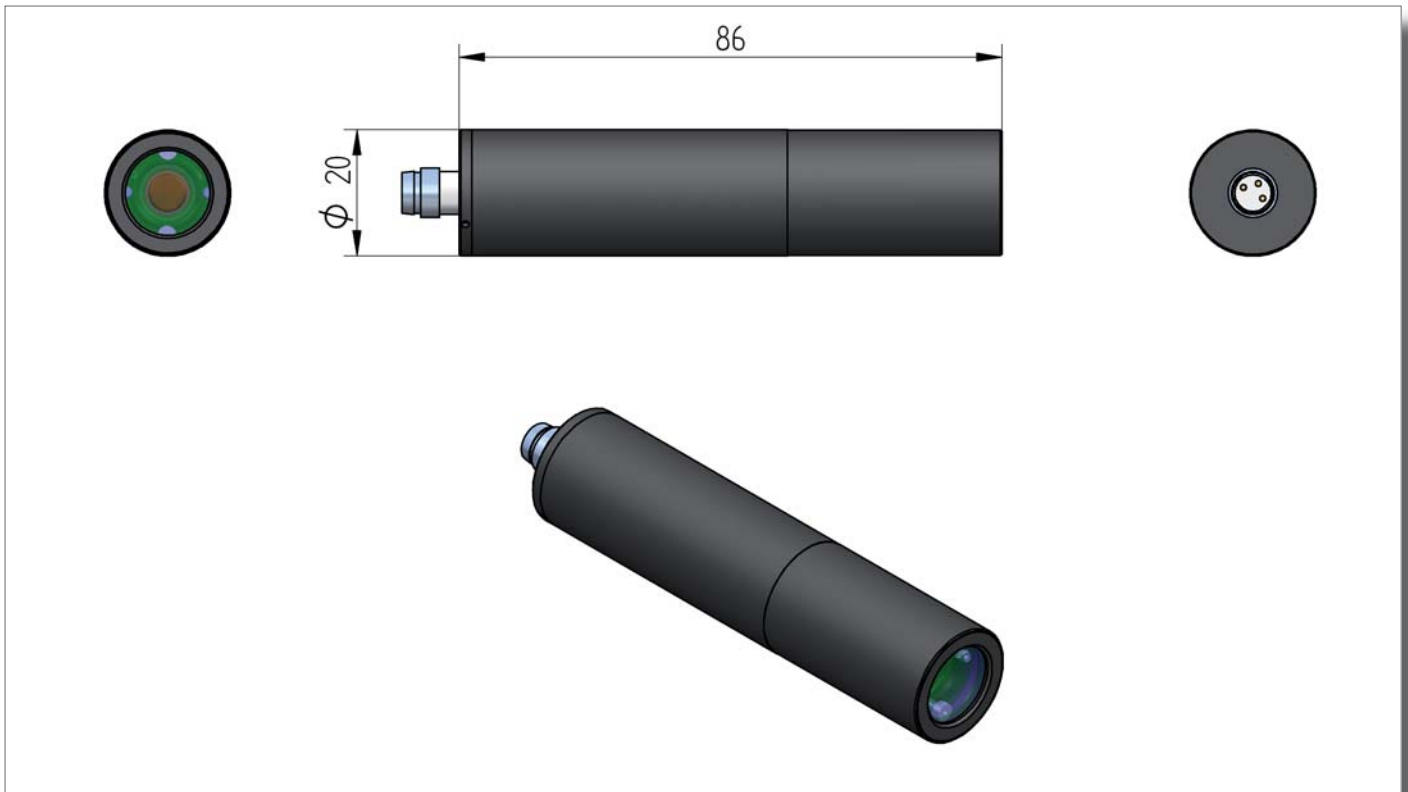

<b>Laser type:</b>	Diode laser up to 90 mW
<b>Laser class:</b>	depending on design
<b>Operating voltage:</b>	5V DC / 24 VDC optional
<b>Electronics:</b>	APC control,
<b>Options:</b>	TTL- (20 kHz), high frequency (up to 100 MHz) modulation, variable or 3 level intensity control
<b>Electr. connection:</b>	depending on model either M8 or M12 connector
<b>Housing:</b>	black anodised Aluminum
<b>IP protection class:</b>	IP63
<b>Optics:</b>	Point, Cylinder lens, Raster lens, Powell lens, DOE
<b>Point spot quality:</b>	elliptic or circular
<b>Line quality:</b>	equally distributed intensity along the line
<b>Focus ability:</b>	factory adjusted according to customer specification

### Pin assignment M8 connector:

Pin 1 Vcc +5V/DC - brown  
Pin 4 Modulation TTL/5V- black  
Pin 3 GND-blue

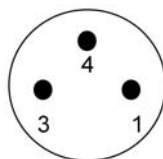

## ZV Diode Laser

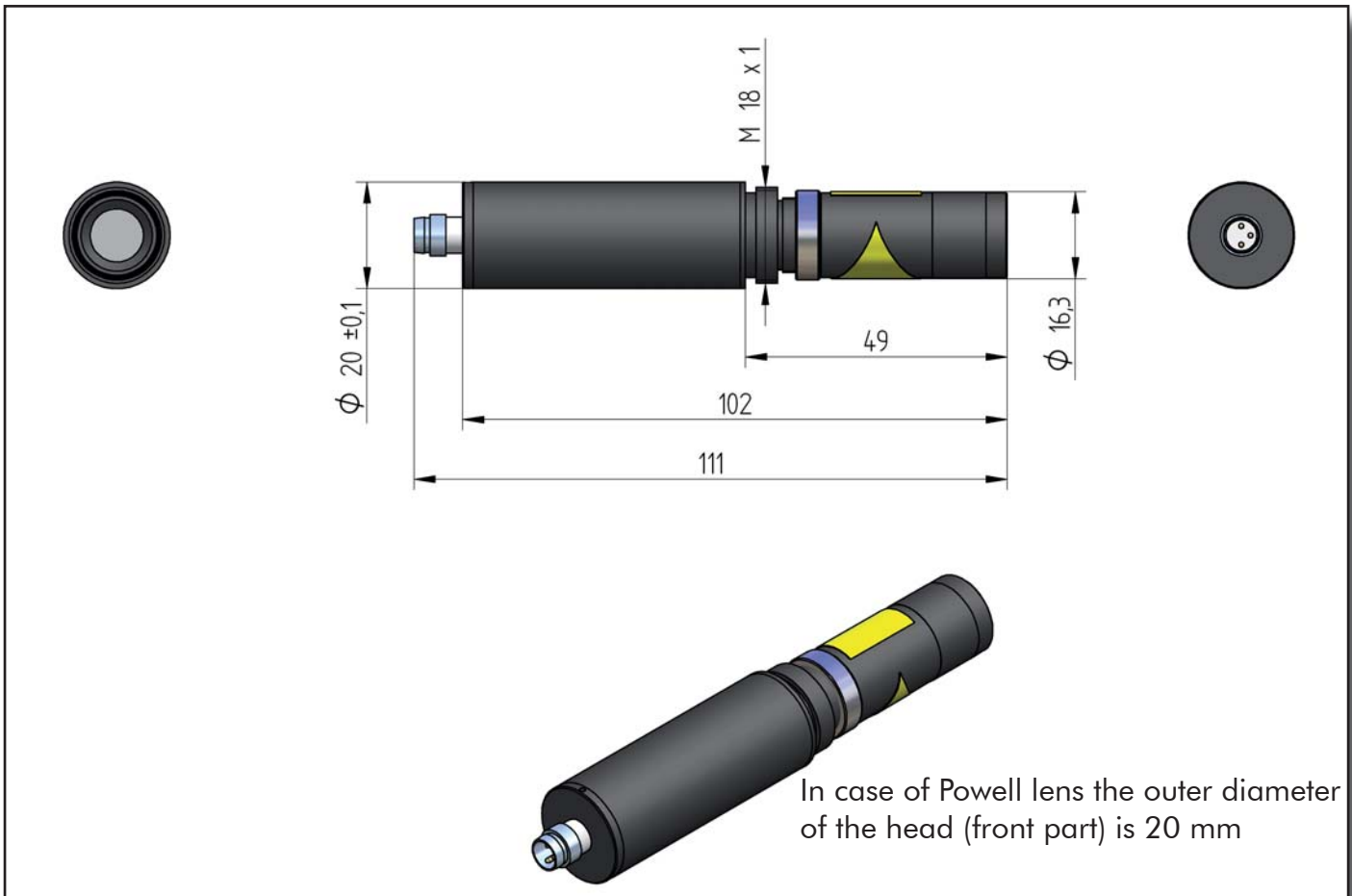

<b>Laser type:</b>	Diode laser up to 90 mW
<b>Laser class:</b>	depending on design
<b>Operating voltage:</b>	5V DC / 24 VDC optional
<b>Electronics:</b>	APC control,
<b>Options:</b>	TTL- (20 kHz), high frequency (up to 100 MHz) modulation, variable or 3 level intensity control
<b>Electr. connection:</b>	depending on model either M8 or M12 connector
<b>Housing:</b>	black anodised Aluminum
<b>IP protection class:</b>	IP63
<b>Optics:</b>	Point, Cylinder lens, Raster lens, Powell lens, DOE
<b>Point spot quality:</b>	elliptic or circular
<b>Line quality:</b>	equally distributed intensity along the line
<b>Focus ability:</b>	hand focusable with counter lock

### Pin assignment M8 connector:

Pin 1	Vcc +5V/DC - brown
Pin 4	Modulation TTL/5V- black
Pin 3	GND-blue

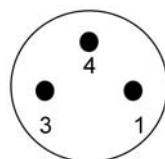

## ZPT with active temperature control

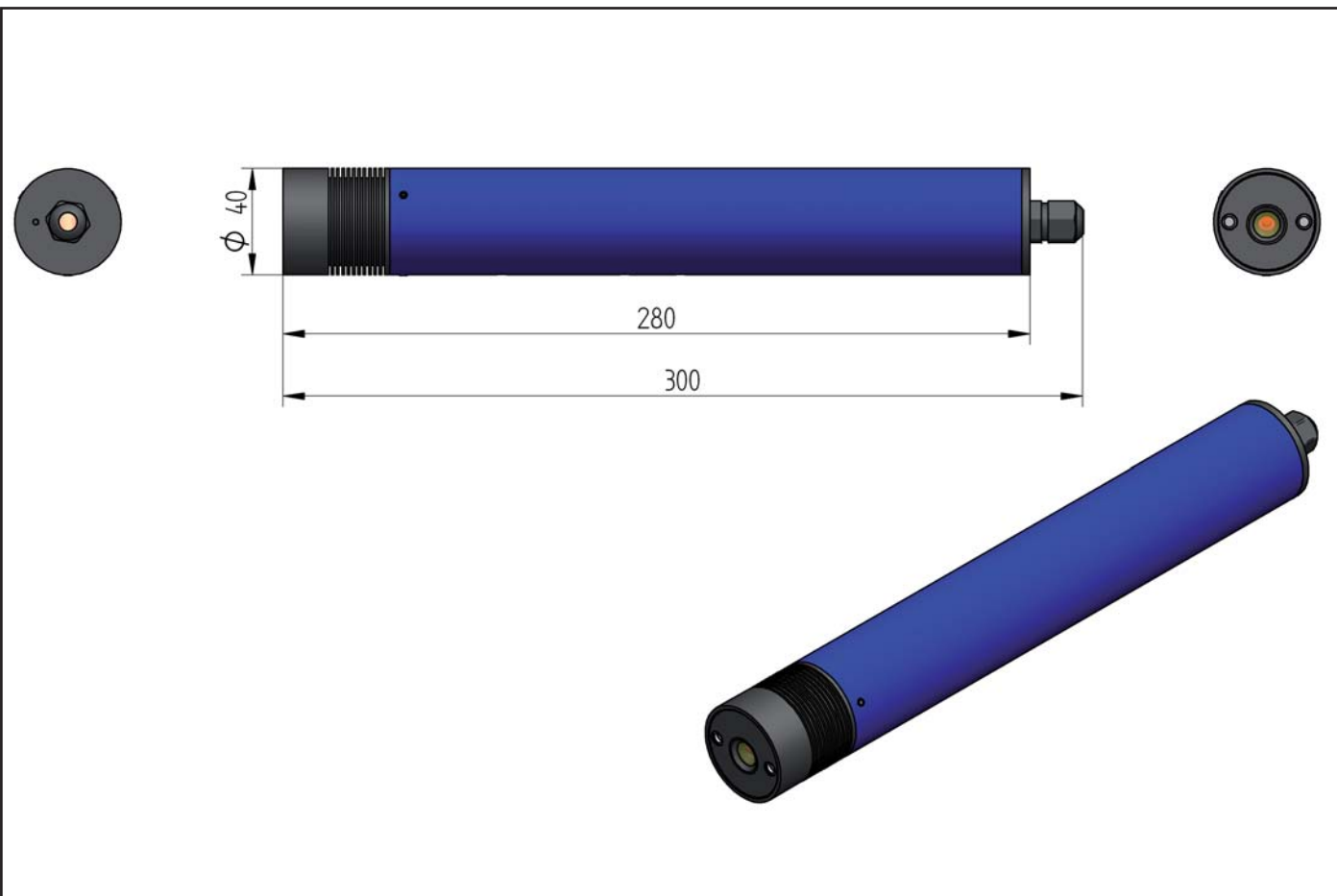

<b>Laser type:</b>	Diode laser up to 90 mW
<b>Laser class:</b>	depending on design
<b>Operating voltage:</b>	90 - 265 VAC
<b>Electronics:</b>	APC control
<b>Electr. connection:</b>	Mains connection with European, Swiss or USA/Japan plug
<b>Housing:</b>	Head: anodised Aluminum Body: Powder coated Aluminum
<b>IP protection class:</b>	IP65
<b>Optics:</b>	Point, Cylinder lens, Raster lens, Powell lens, DOE
<b>Point spot quality:</b>	elliptic or circular
<b>Line quality:</b>	equally distributed intensity along the line
<b>Focus ability:</b>	Tool focusable without removal of the optics
<b>Operating temperature</b>	- 20°C to 50°C

## ZQ High laser power with active temperature control



### Main features

- high stabilised diode laser for precision measurements (wave length stability better than 0,3 nm)
- Temperature and power adjustment via separate controller
- very good coaxiality beam to housing
- customized point and line raster glass DOEs
- coupling into multi mode fiber

<b>Laser type:</b>	Diode laser up to 1.5 W, DPSS up to 20 mW
<b>Laser class:</b>	depending on design
<b>Operating voltage:</b>	90 - 265 VAC or 5 VDC
<b>Electronics:</b>	APC control
<b>Electr. connection:</b>	Plug line cord Europe, Switzerland or USA/Japan
<b>Housing:</b>	black anodised Aluminum
<b>IP protection class:</b>	IP65
<b>Optics:</b>	Point, Cylinder lens, Raster lens, Powell lens, DOE
<b>Point spot quality:</b>	elliptic or circular
<b>Line quality:</b>	equally distributed intensity along the line
<b>Focus ability:</b>	hand focusable with counter lock

## DPSS version

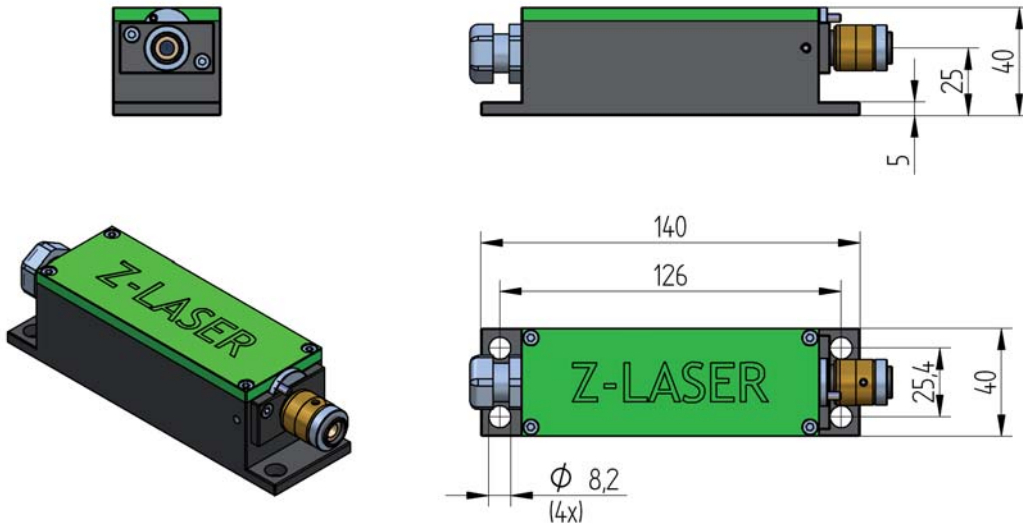

## Diode version

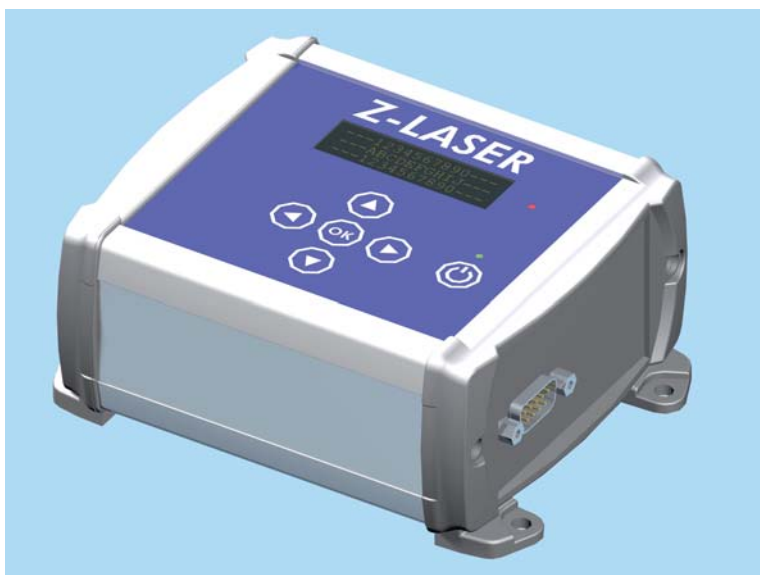
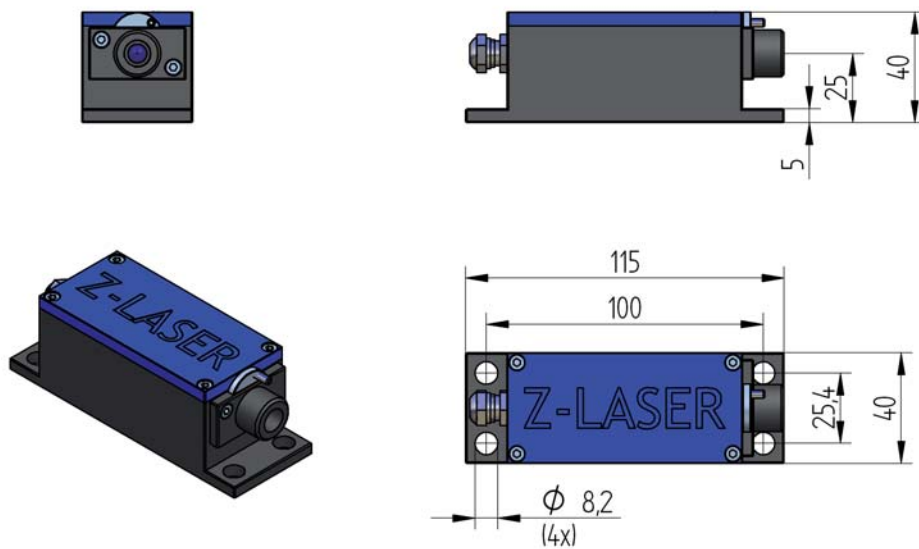

## LCD Display and Keypad

- Fixed Temperature and power (DPSS/Diode laser)
- Wavelength tuning by temperature variation (Diode Laser)
- Remote software control via USB-interface
- Temperature and Power setting
- Display of system parameter (temperature, power, wave length, operation hours etc.)

## Z-LASER Mountings

### HX-11

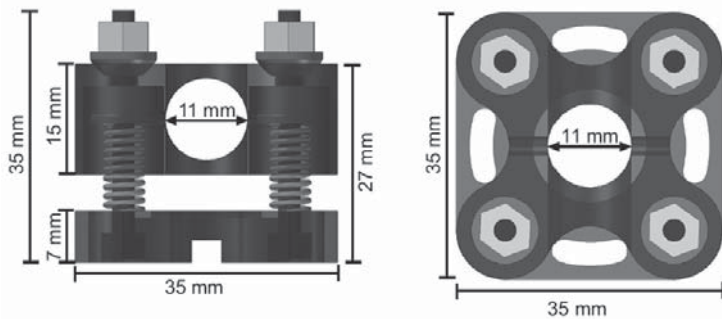

### HX-11 for 11 mm laser HX-20 for 20 mm laser

- fixed by two screws through elongated holes
- shock-free, very precise adjustment possible up to 1/10 mm in a distance of 1000 mm
- stays in the required position
- regulatable in 6 directions
- rotatable around  $\pm 5^\circ$
- patented

### H2-20

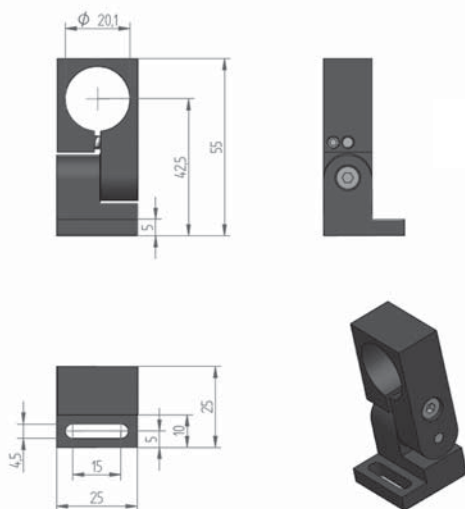

### H2-20 for 20 mm laser H2-40 for 40 mm laser

- fixed with two screws through elongated holes
- tiltable

### H4-20

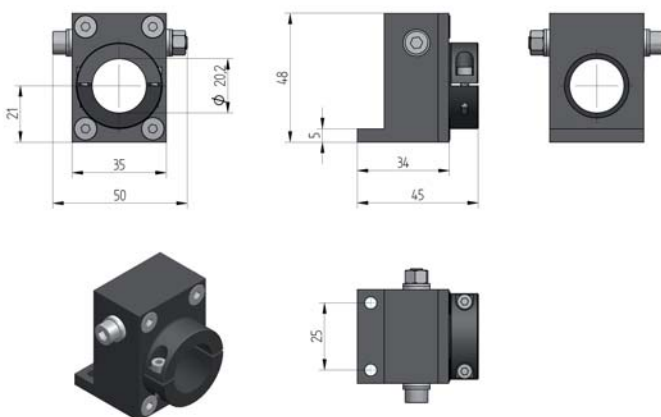

### H4-20 for 20 mm laser

- fixed with two screws through elongated holes
- coaxially rotatable around the axis

## H6-20

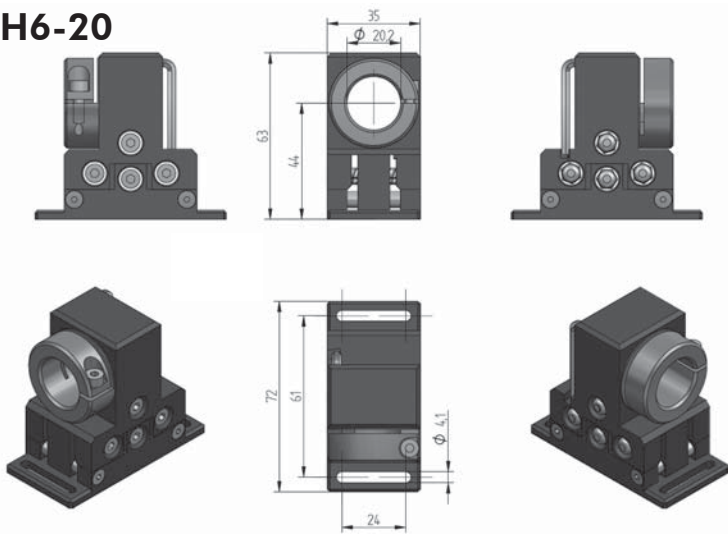

## H6-20 for 20 mm laser H6-40 for 40 mm laser

- Tool adjustable
- Rotation around 360°
- Parallel-movement  $\pm 4$  mm
- Angular shift  $\pm 2,5^\circ$ , corresponds for 1000 mm distance approximately  $\pm 50$  mm

## MXYZ-20 for 20 mm laser

- Fine thread, hand adjustable
- Rotation around 360°
- Parallel-movement  $\pm 10$  mm
- Angular shift  $\pm 10^\circ$
- Self-locking

## MXYZ

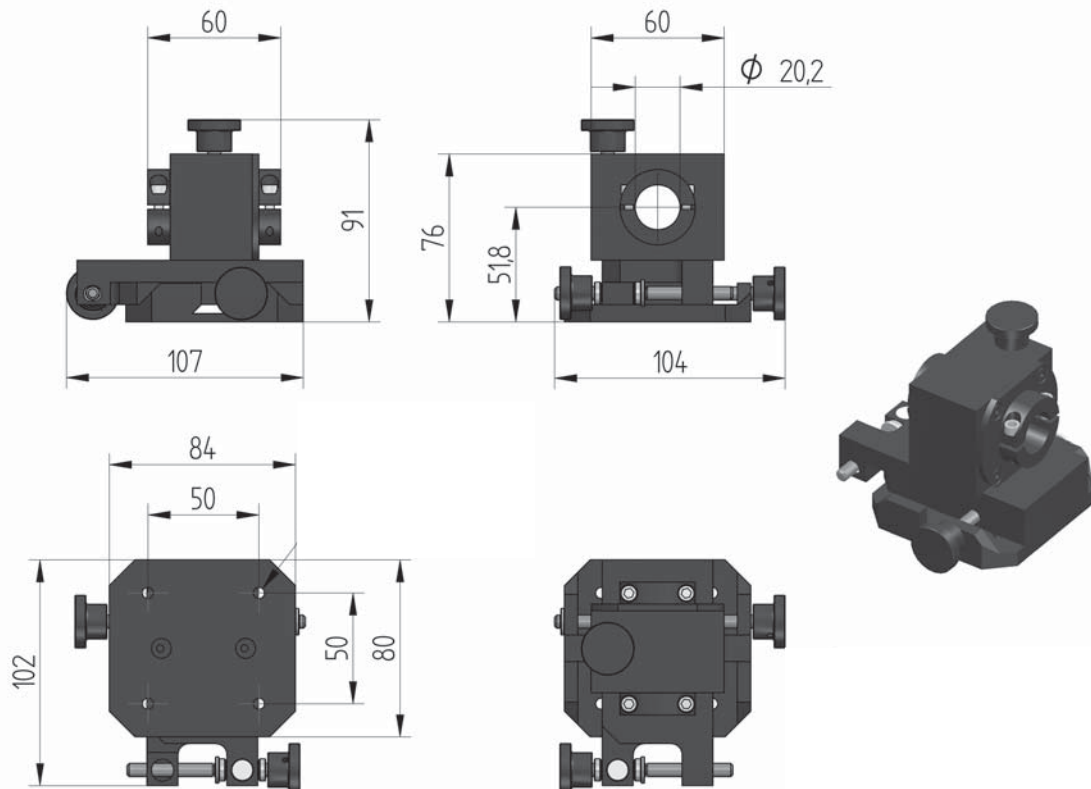

## Questionnaire for special models - Reply by fax to: +49 / 761 / 296 44 55

If you need a model with specifications other than the ones described above, please fill in this questionnaire and fax it to us. We will check immediately if we can provide you with the desired product! **Please give as exact and detailed information as possible!**

### Laser-Module:

**Wavelength:**

635 nm    660 nm    785 nm   \_\_\_\_\_ nm

**Output power:**

1mW    5mW    15mW    30 mW    90 mW    250 mW  
\_\_\_\_\_ mW / min. \_\_\_\_\_ mW max. \_\_\_\_\_ mW

**Laser class to be kept:**

2    2M    3R    3B

### Projection:

**Line:**

Length: \_\_\_\_\_ mm   Width: \_\_\_\_\_ mm  
Mounting height: \_\_\_\_\_ cm   Angle: \_\_\_\_\_ °  
Light distribution:    Gauß    Rectangle

**Point:**

round point   :    elliptic point:    1:2    1:1.5  
Diameter: \_\_\_\_\_ mm in a distance of \_\_\_\_\_ mm  
Diameter directly after beam exit: \_\_\_\_\_ mm  
Beamdivergence \_\_\_\_\_ mrad

**DOE:**

Required pattern: \_\_\_\_\_  
Mounting height: \_\_\_\_\_ cm   Angle: \_\_\_\_\_ °  
Max. intensity variation: +/- \_\_\_\_\_ %

**Installation/Application:**

\_\_\_\_\_  
\_\_\_\_\_  
\_\_\_\_\_

If possible, please send us a photo or a sketch of the application!

**Input voltage/-power:**

DC    AC   \_\_\_\_\_ V   \_\_\_\_\_ mA

**Reverse polarity protection:**

Yes    No

**Operating temperature:**

from \_\_\_\_\_ °C / F to \_\_\_\_\_ °C / F

**Dimensions of the laser:**

Diameter: \_\_\_\_\_ mm x Length: \_\_\_\_\_ mm

**Material:**

Aluminium, anodised    stainless-steel    Copper

\_\_\_\_\_ Colour: \_\_\_\_\_

**Cable length:**

\_\_\_\_\_ mm Plug type: \_\_\_\_\_

**Demand (Pcs./Year):**

\_\_\_\_\_ Pcs.

**Target price:**

\_\_\_\_\_ € / Pc. (for large number of items)

Company: \_\_\_\_\_

Contact person: \_\_\_\_\_

Address: \_\_\_\_\_

Zip / City: \_\_\_\_\_

Phone: \_\_\_\_\_

Fax: \_\_\_\_\_

E-mail: \_\_\_\_\_

www: \_\_\_\_\_

05/ 2007